

WALL CABINET



WALL CABINET

Overall Dimensions:

900 (w) x 380 (d) x 600 mm (h)

Shipping Dimensions:

900 (w) x 380 (d) x 600 mm (h)

Shipping Weight: 52 kg

Material:

Top: 1 mm 430 grade stainless steel

Door / Side / Internal:

0.8 mm 430 grade stainless steel

PRODUCT CODE: WALLCAB900

Brayco Stainless Steel is made from 95% recycled materials

FEATURES AND BENEFITS

- High Grade Stainless Steel.
- Construction: Our units are fully stainless steel. Very sturdy.
- Adjustable Shelf.
- 2 Sliding Doors.
- Supplied Fully Assembled: Simply attach feet/castors. No extra cost.

INSTALLATION

- 4 holes in back of cabinets for installation. (Fixtures not included)

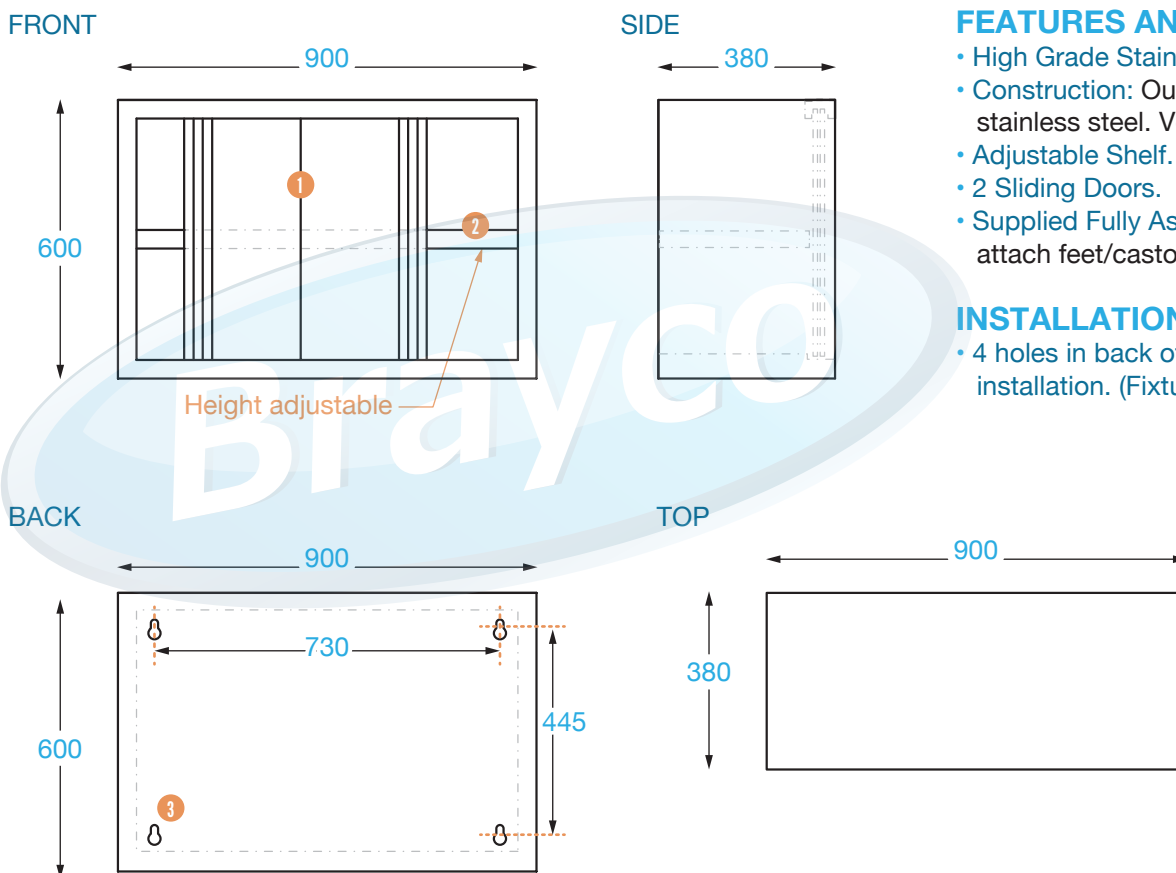

COMPONENTS

- 1 Sliding doors Top mounted ball-bearing stainless runners
- 2 Inner shelf 0.8 mm (height adjustable)
- 3 Installation 4 holes for installation (fixture not included)

It is important that your stainless steel is kept clean to extend the lifetime of the product.



Brisbane • Sydney • Melbourne • Hobart • Adelaide • Perth • Auckland
 For more info please contact your nearest Brayco Branch 1300 272 926 | brayco.com.au

Whilst all care has been taken when compiling this information, designs & dimensions shown are indicative only and should not be relied upon without prior approval. Brayco reserves the right to make changes without notice.