

# 1700 MM HIGH PREMIUM COOLROOM SHELVING

## Load Capacity:

### Straight configuration or as one bay:

- 925, 1075 and 1225mm long  
- 250kg per shelf (or 85kg per shelf with castors)
- 1375 and 1525mm long units  
- 200kg per shelf
- 1825mm long unit – 180kg per shelf
- 1975mm long unit – 150kg per shelf

### L shaped configuration:

- 925, 1075 and 1225mm long units  
- 150kg per shelf
- 1375 to 1975mm long units  
- 100kg per shelf

Note: Load must be evenly spaced across the length of the shelf.



## PREMIUM SHELVING UNIT

**Overall Height:** 1700 mm

**Depth:** 355 mm, 450 mm, 610 mm

**Load Capacity:**

Please refer to loading capacity tab

**Material:**

Aluminium square post and rails

Plastic shelves

**Warranty:**

10 year warranty



### 355 mm Deep

PS1436-17	925 x 355 mm
PS1442-17	1075 x 355 mm
PS1448-17	1225 x 355 mm
PS1460-17	1525 x 355 mm
PS1472-17	1823 x 355 mm

### 450 mm Deep

PS1836-17	925 x 450 mm
PS1842-17	1075 x 450 mm
PS1848-17	1225 x 450 mm
PS1860-17	1525 x 450 mm
PS1872-17	1825 x 450 mm
PS1878-17	1975 x 450 mm

### 610 mm Deep

PS2436-17	925 x 610 mm
PS2442-17	1075 x 610 mm
PS2448-17	1225 x 610 mm
PS2454-17	1375 x 610 mm
PS2460-17	1525 x 610 mm
PS2472-17	1825 x 610 mm
PS2478-17	1975 x 610 mm

FRONT

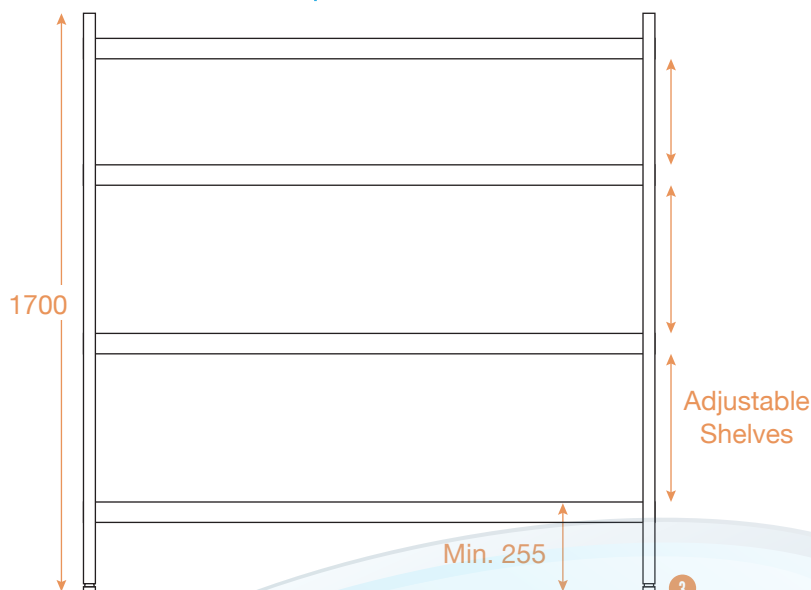

TOP

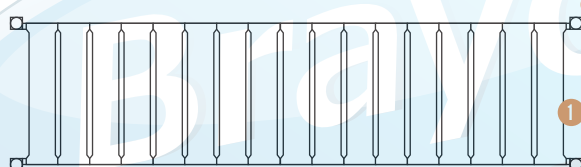

## FEATURES AND BENEFITS

- **Supplied Flat Pack:** Quick and easy to assemble.
- **Adjustable Feet:** Supplied attached to leg.
- **4 Adjustable Height Shelves.**
- **Extra Shelves Available.**
- **Rust Resistant.**
- **Dishwashable:** Shelf slats are easy to remove which makes cleaning a breeze. Wipe clean any spills or just pull out and wash in the sink.
- **Suitable for temperatures from -38°C to 88°C.**
- **Completely Versatile:** Mix and match sizes and depths to fully maximise the space in your coolroom. Corner attachments mean fewer posts allowing for better access.
- **Patented Locking System:** Ensures the unit carries the weight required in any kitchen.
- **Please contact us for more configurations.**

## COMPONENTS

- 1 Shelf Aluminium rail, plastic slats: 75mm (edge) to 60mm (middle) wide
- 2 Post 35 x 35mm aluminium post
- 3 Feet Adjustable up to 30mm



Brisbane • Sydney • Melbourne • Hobart • Adelaide • Perth • Auckland  
For more info please contact your nearest Brayco Branch 1300 272 926 | brayco.com.au

# 1700 MM HIGH PREMIUM COOLROOM SHELVING

355mm Deep

450mm Deep

610mm Deep

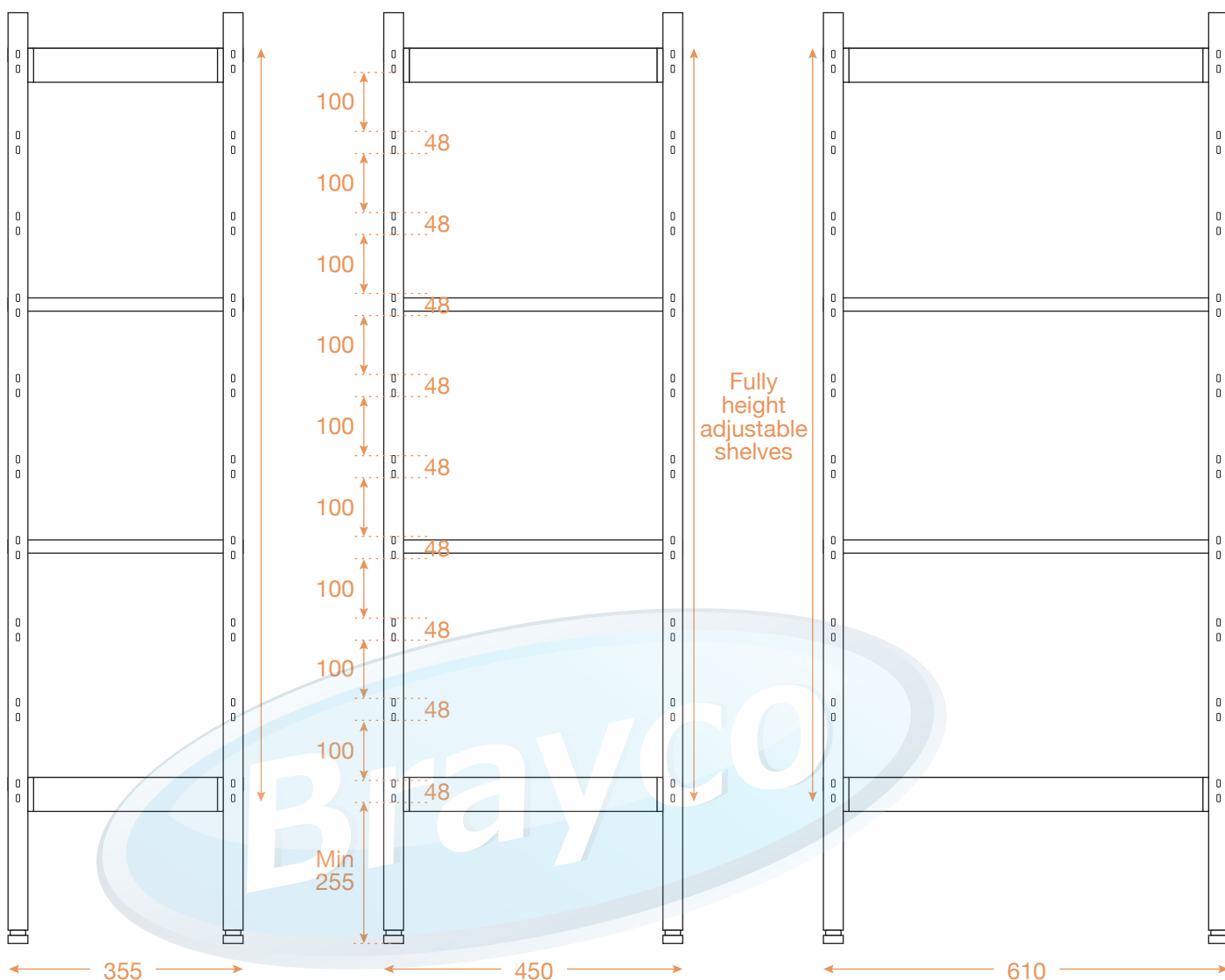

## HOW TO CREATE 'U', 'L' OR STRAIGHT CONFIGURATIONS

**'U' Shape:** To create a 'U' shape configuration you will need 2 complete bays and additional shelves for the middle of the 'U' shape. When connecting the complete bay to the shelf you will need a pair of corner connectors and 2 slats with slots at each end of the shelf. Confusing? We have made it easier for you – simply order a connection pack to fit the depth of each complete unit.

**'L' Shape:** When connecting the 1st Bay to the Extra Bay to create a 'L' shape you will need 1 connector pack for the depth of the 1st bay. The connector pack contains 2 Corner Connectors and 2 Plate slats with slots for each shelf.

**Straight:** Simply add your extra bay to the end of the 1st Bay. No Extra parts are required.

## UPGRADE OPTIONS

- **Castors or Heavy Duty Castors:** Create a mobile unit.
- **Connector Pack:** Create L-shape or U-shape configuration by using connectors.

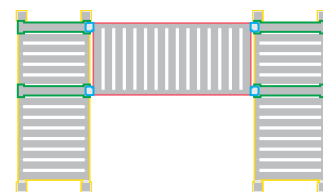

U shape configuration

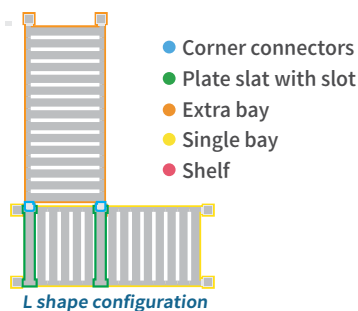

L shape configuration



Brisbane • Sydney • Melbourne • Hobart • Adelaide • Perth • Auckland  
For more info please contact your nearest Brayco Branch 1300 272 926 | [brayco.com.au](http://brayco.com.au)